



安徽泽顺新材料科技有限公司
Anhui Zeshun new material Technology Co., LTD

Tel: (+86)13958230400
E-mail: admin@zheshunfloor.com / 243865689@qq.com
web: www.zeshunfloor.com



安徽泽顺新材料科技有限公司
Anhui Zeshun New Material Technology Co., Ltd

Sustainable Woods Greener Future

We source timber responsibly, safeguarding forests.

Our commitment to sustainability is evident in every step of production.

By choosing us, you're contributing to a greener future, as we strive to balance business growth with environmental protection in the wood industry.

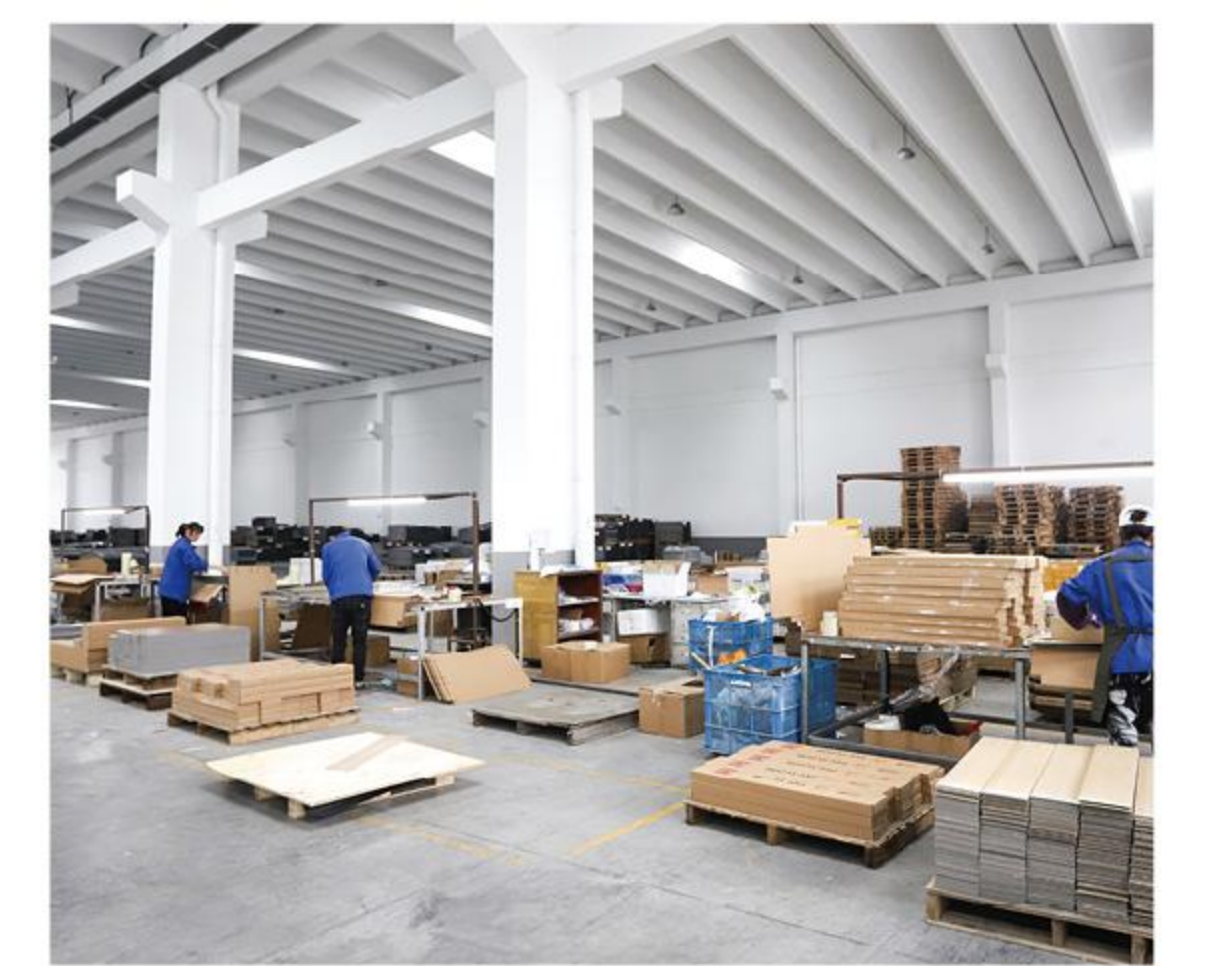

公司介绍

安徽泽顺新材料科技有限公司始终聚焦于新材料领域，主营业务布局广泛且多元。

公司专注于生产 PVC、SPC 石塑地板，凭借卓越的品质与性能，产品不仅畅销国内市场，更远销海外，全面达产后预计年产量可达 800 万平方米。公司大力拓展货物和技术进出口业务，积极参与国际市场竞争，不断提升品牌的国际影响力。

自成立以来，公司依托先进的生产设备、持续创新的工艺技术以及始终如一的优质产品，在激烈的市场竞争中脱颖而出，将继续深耕新材料领域，不断加大研发投入，提升创新能力，为行业发展贡献更多力量，创造更多辉煌成就。

Company introduction

Established in September 2021, Anhui Zeshun New Material Co., Ltd. is based in the Langxi Economic Development Zone, Xuancheng, Anhui. representative and a registered capital of 5.8 million RMB, it operates as a vibrant limited liability company.

Our business spans engineering R&D, manufacturing and sales of floors, plastic products, and a wide range of building materials. We also engage in international trade. With a 320 - million - yuan investment and modern facilities, we mainly produce PVC and RSPC plastic floors for both domestic and overseas markets. As we expand, our future looks bright.

Main Business of Anhui Zeshun New Material Technology Co., Ltd.

- Floor Manufacturing and Sales
- Plastic Products Business
- Related to Building Materials
- Import and Export Business



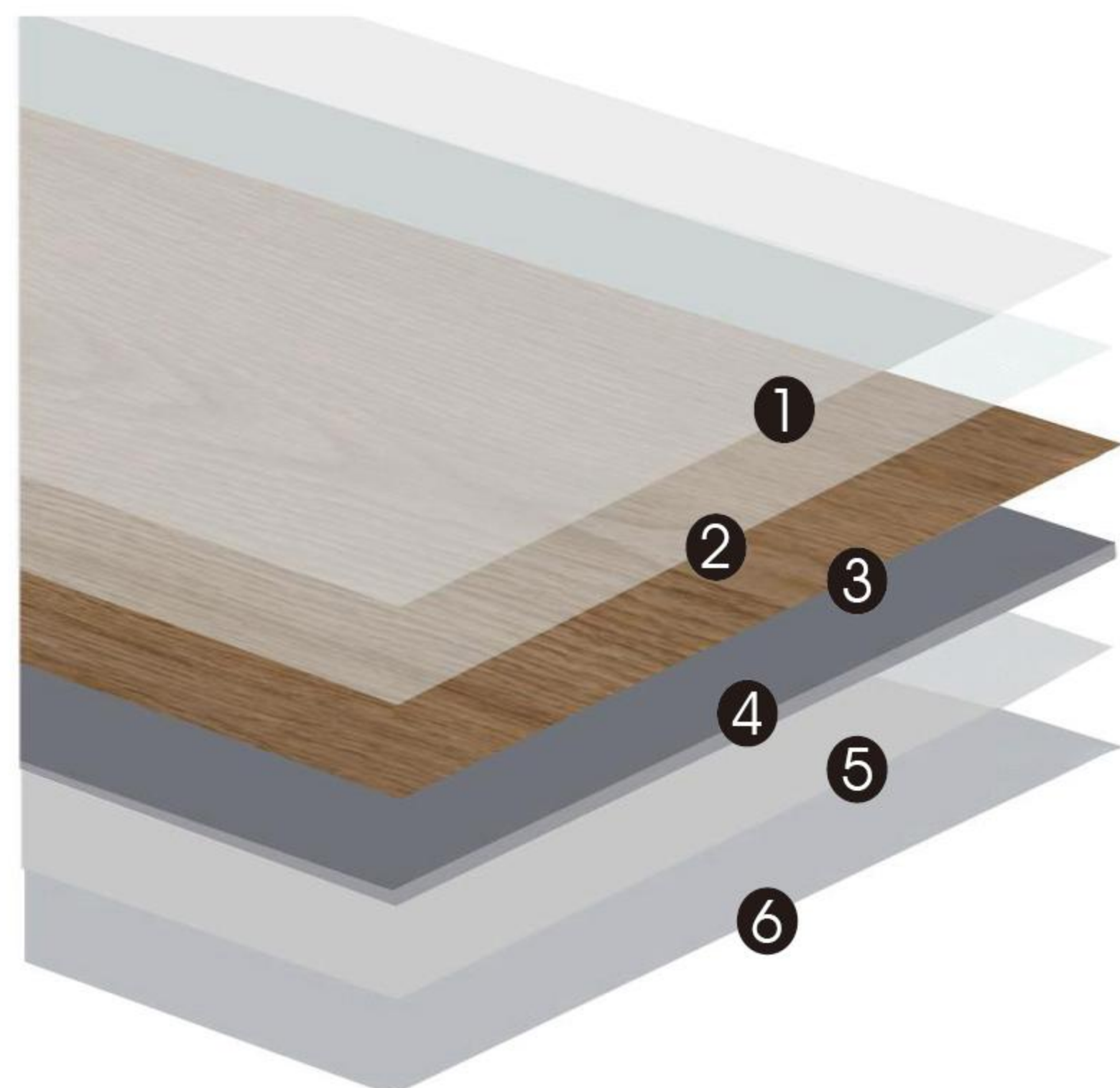

PEEL & STICK

Technical data sheet
技术数据表



- ① UV layer - UV 涂层
- ② Wear layer - 耐磨层
- ③ Decor film layer - 彩膜层
- ④ PVC stone plastic layer - PVC 石塑层
- ⑤ Adhesive layer - 粘合层
- ⑥ Isolation layer - 隔离膜



Size 规格	Peel & Stick	Length from 304.8 to 1219.2mm Width from 304.8 to 914.4mm 长度从 304.8 到 1219.2 毫米 宽度 304.8 到 914.4 毫米
Thickness 厚度	Peel & Stick	From 1mm to 3mm 从 1mm 到 3 毫米
UV Option UV 淋膜	Peel & Stick	Ceramic Coating/Diamond Coating 陶瓷珠 / 晶钻
Wear Layer 耐磨层		0.07-0.30 mm
IXPE		1.0 / 1.5 / 2.0 mm
Surface Treatment 表面处理		Wood Emboss, Glossy, Granite 木纹、同步对花、水晶面、板岩纹
Edge Treatment 边缘处理		  

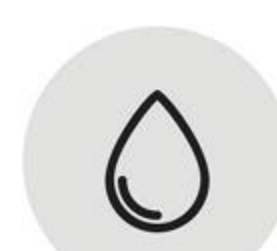

Water proof



Will not expand or contract



Easy to Install



Installation on any surface



Covers minor floor imperfections



Superior scratch resistance



Reduces noise

PEEL & STICK

ZS-980-2

1000X1000MM

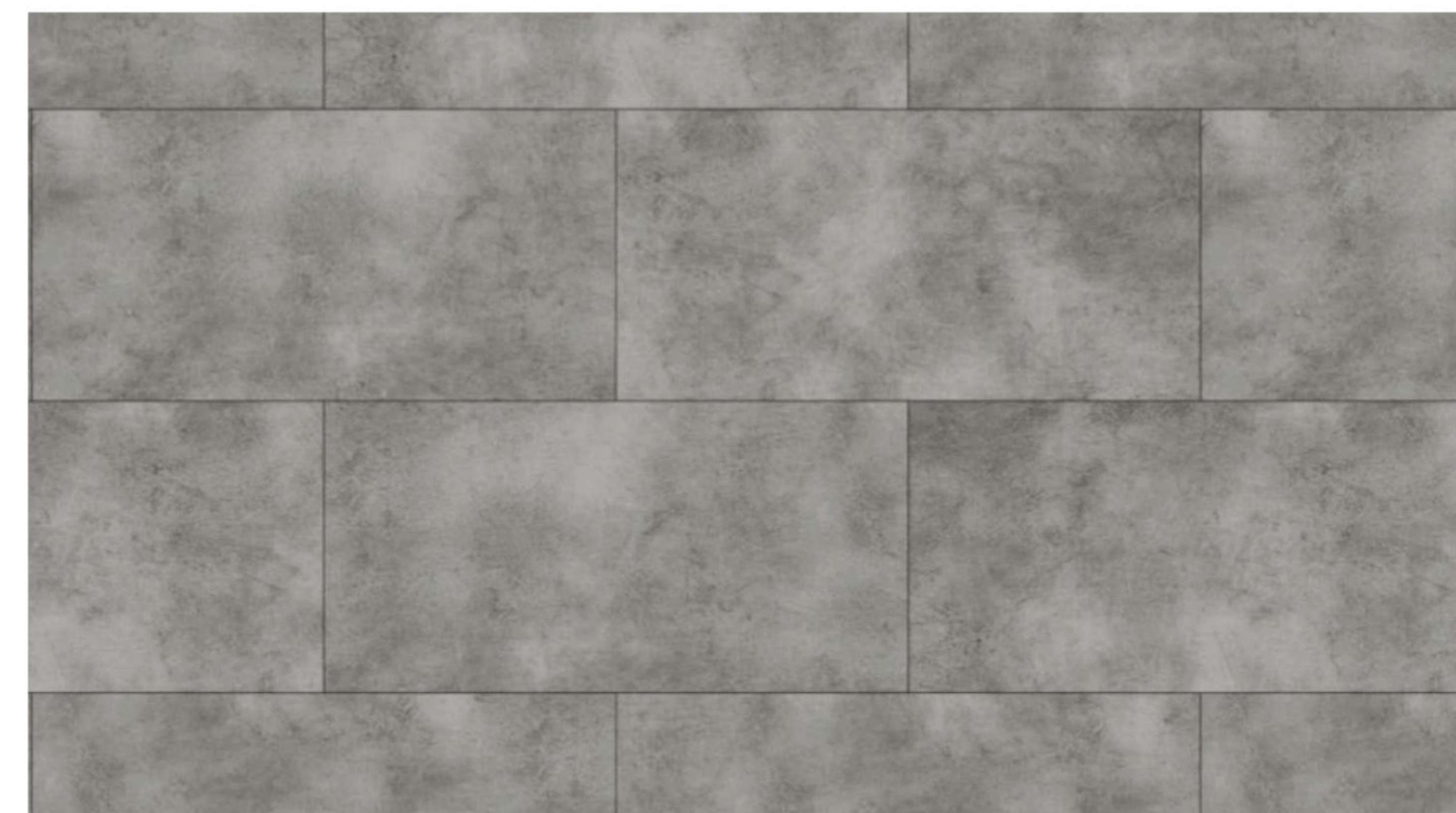

SPC | Technical data sheet

技术数据表

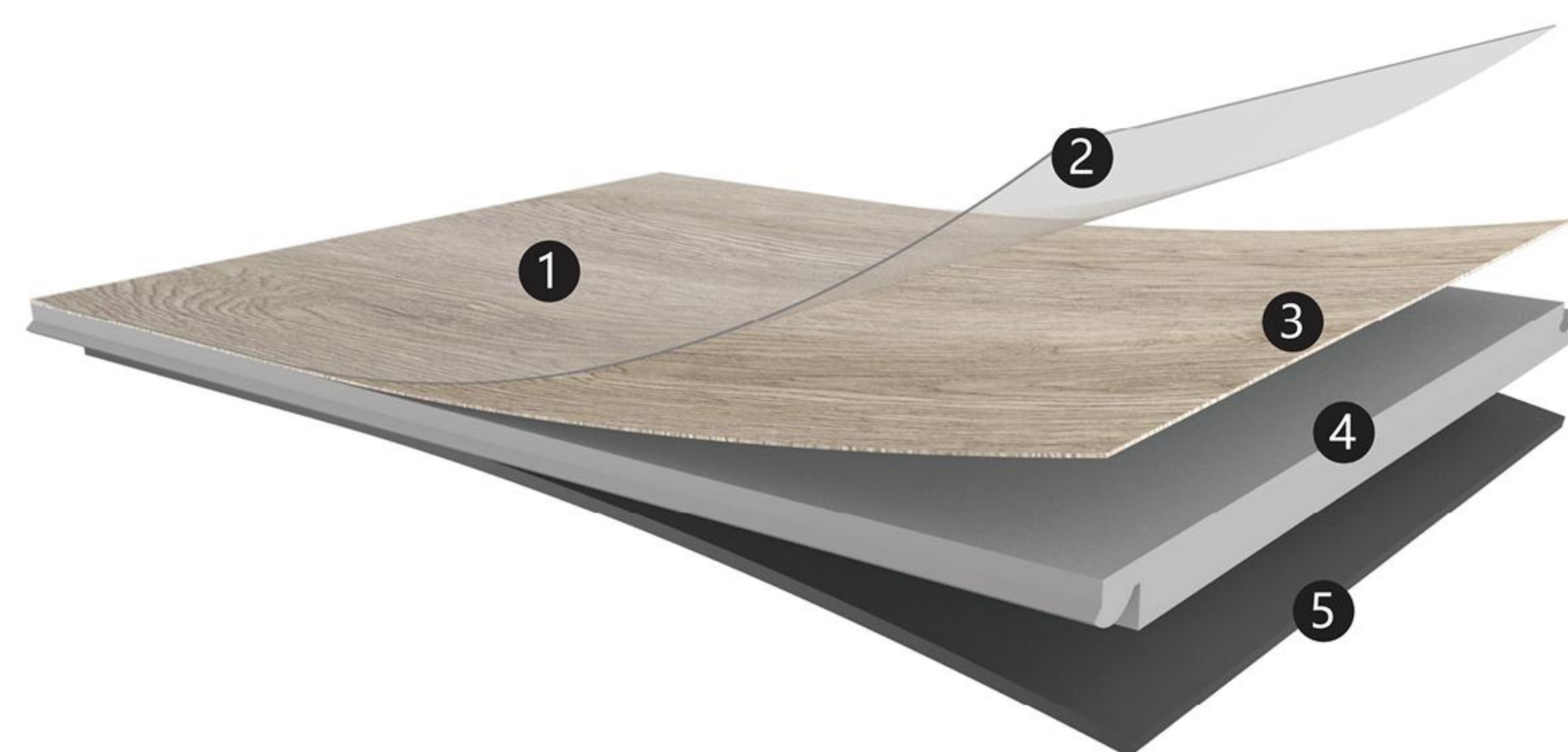

CLICK SYSTEM SERIES

- ① UV Coating - UV 漆
- ② Wear layer - 耐磨层
- ③ Decor film layer - 彩膜层
- ④ Rigid core - 基材
- ⑤ Attached pad - 静音垫 (IXPE, EVA)





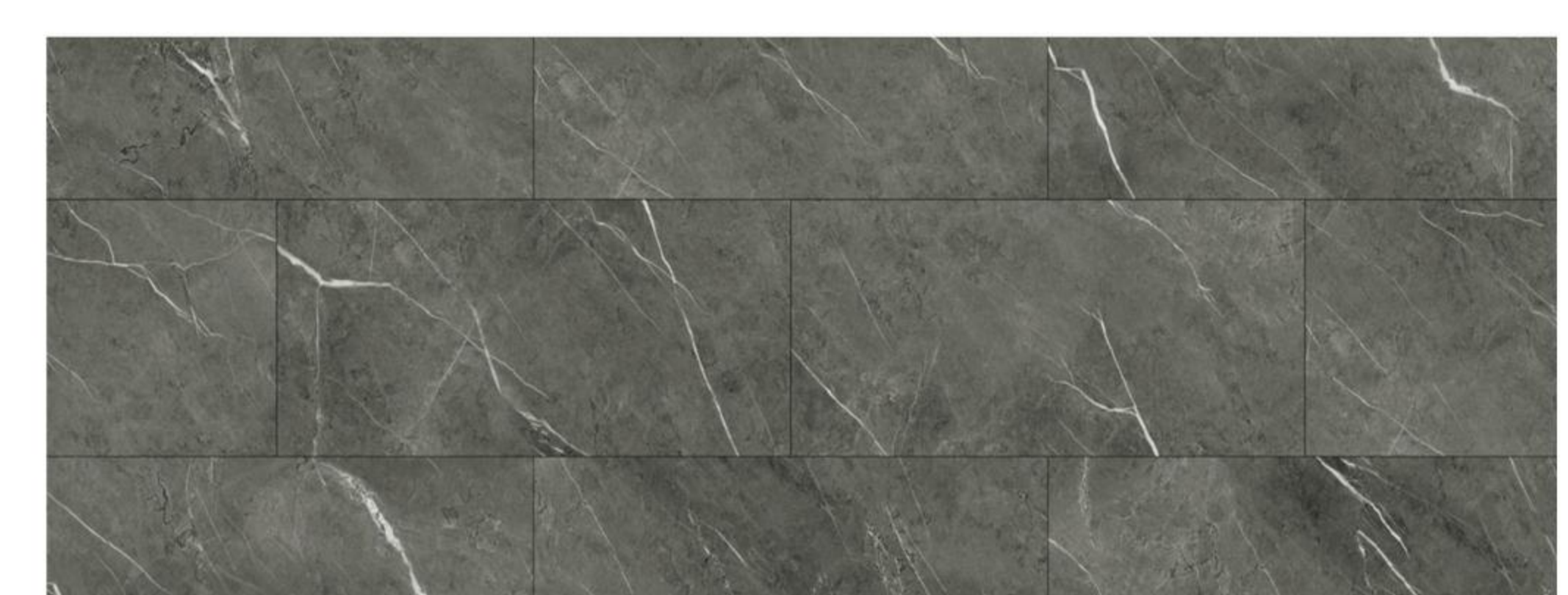



Size 规格	SPC	Length from 590 to 1800mm Width from 118 to 600mm 长度从 590 到 1800 毫米 宽度 118 至 600 毫米
Thickness 厚度	SPC	From 3.2mm to 8.0mm 从 3.2mm 到 8.0 毫米
UV Option UV 淋膜	SPC	Ceramic Coating/Diamond Coating 陶瓷珠 / 晶钻
Wear Layer 耐磨层		0.15 / 0.30 / 0.50 mm
IXPE		1.0 / 1.5 / 2.0 mm
Surface Treatment 表面处理		Wood Emboss, EIR, Crystal, Granite 木纹、同步对花、水晶面、板岩纹
Edge Treatment 边缘处理		  



ZS-1004-1
1300X1270MM





-  Water proof
-  Will not expand or contract
-  Easy to Install
-  Installation on any surface
-  Covers minor floor imperfections
-  Superior scratch resistance
-  Reduces noise

LVT GLUE DOWN | Technical data sheet

技术数据表



- ① UV Coating - UV 漆
- ② Wear layer - 耐磨层
- ③ Decor film layer - 彩膜层
- ④ LVT middle & bottom Layer - LVT 中料和底料

Size 规格	LVT	Length from 590 to 1800mm Width from 118 to 600mm 长度从 590 到 1800 毫米 宽度 118 至 600 毫米
Thickness 厚度	LVT	From 3.2mm to 8.0mm 从 3.2mm 到 8.0 毫米
UV Option UV 淋膜	LVT	Ceramic Coating/Diamond Coating 陶瓷珠 / 晶钻
Wear Layer 耐磨层		0.15 / 0.30 / 0.50 mm
IXPE		1.0 / 1.5 / 2.0 mm
Surface Treatment 表面处理		Wood Emboss, EIR, Crystal, Granite 木纹、同步对花、水晶面、板岩纹
Edge Treatment 边缘处理		  



Water proof



Will not expand or contract



Easy to Install



Installation on any surface



Covers minor floor imperfections



Superior scratch resistance



Reduces noise



LVT GLUE DOWN

ZS-YC1005-4

WOOD: PINE
SPEC: 1000X1570MM

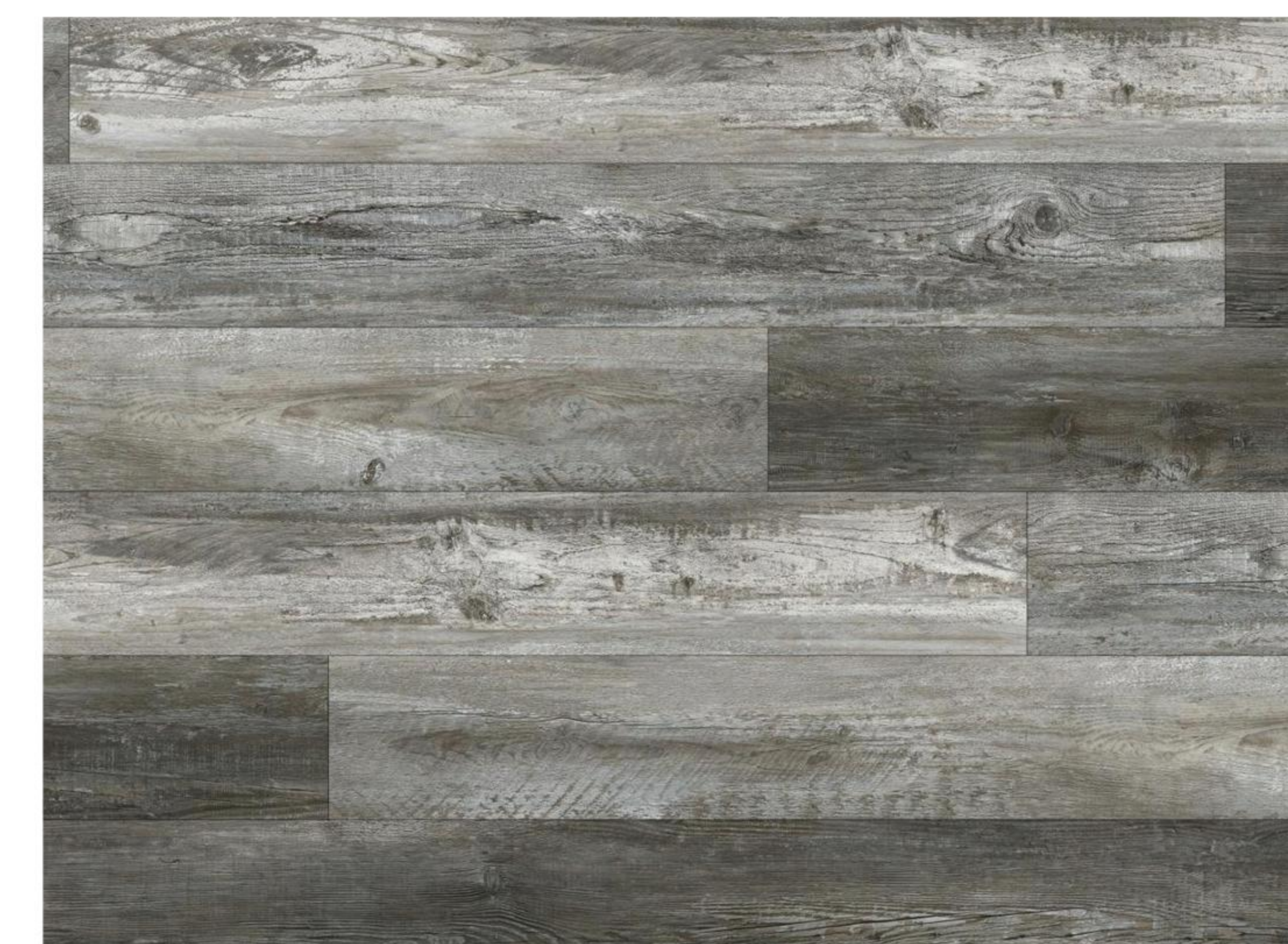

WALL STICKER | Technical data sheet 技术数据表

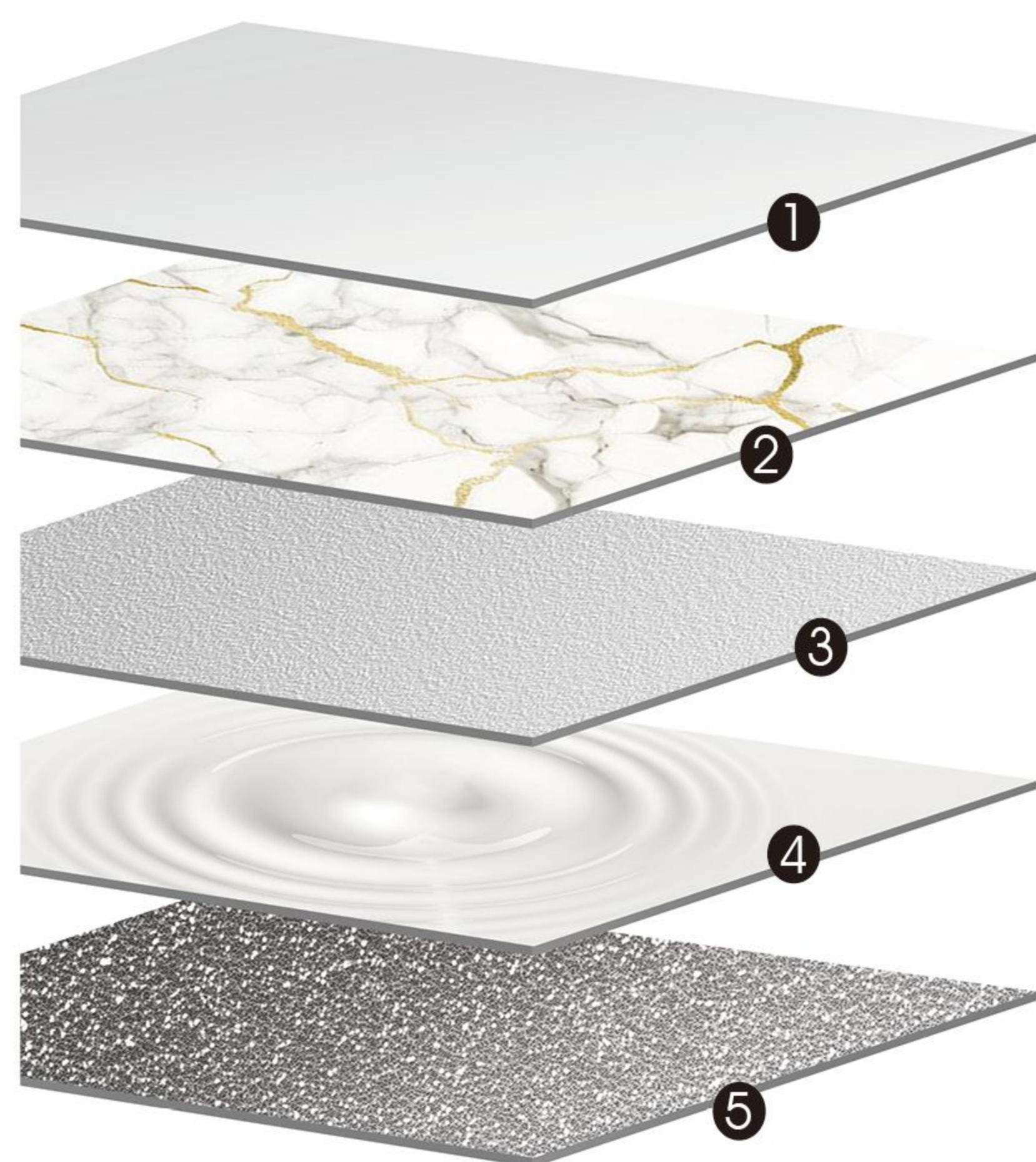

- ① Waterproof and wear-resistant layer
- 防水耐磨层
- ② high definition printing layer
- 高清印花层
- ③ sound insulation and anti-collision
- 隔音防撞保温层
- ④ Environment friendly water-based adhesive
- 环保水性胶层
- ⑤ aliminum foil paper layer
- 格拉辛底膜层

Size
规格

Length from 600 to 5000mm
Width from 300 to 1200mm
长度从 600 到 5000 毫米
宽度 300 到 1200 毫米

Thickness
厚度

2.5mm

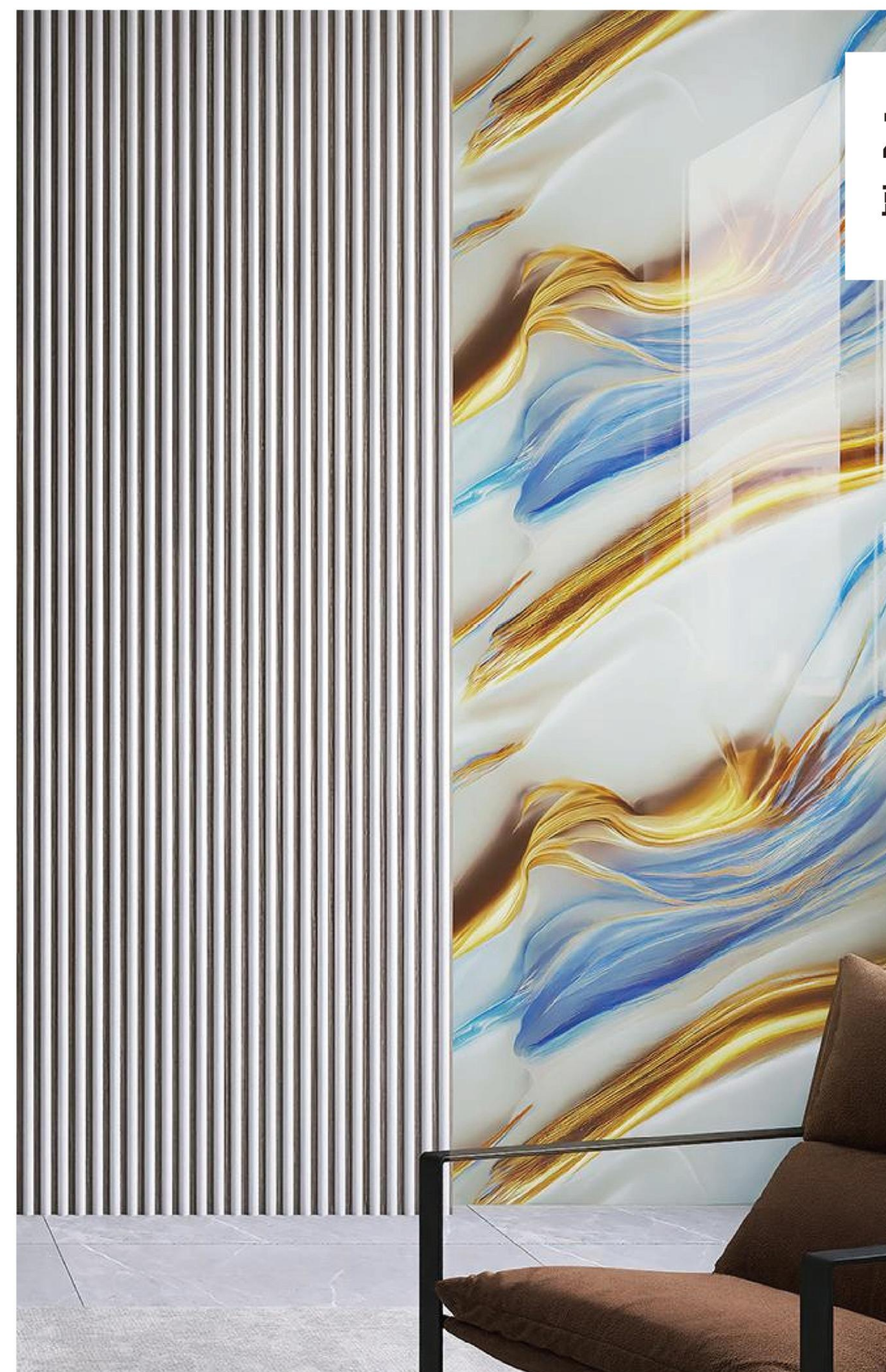

ZS-CZT193 蓝羽鎏金

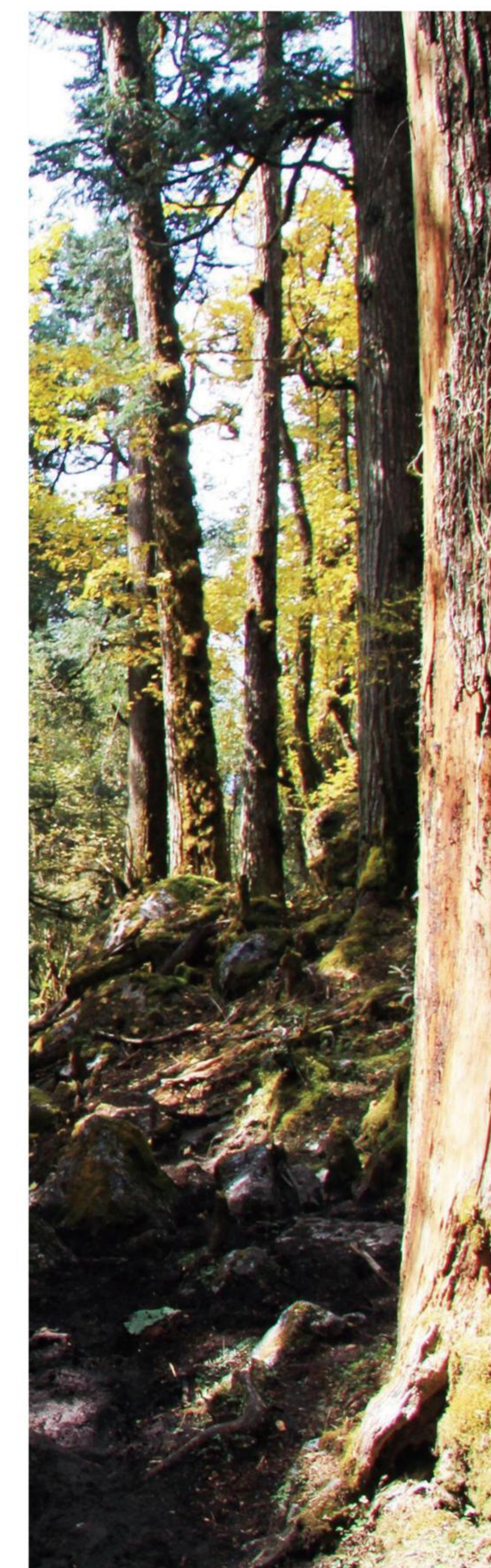

ZS-CZT066



ZS-CZT117

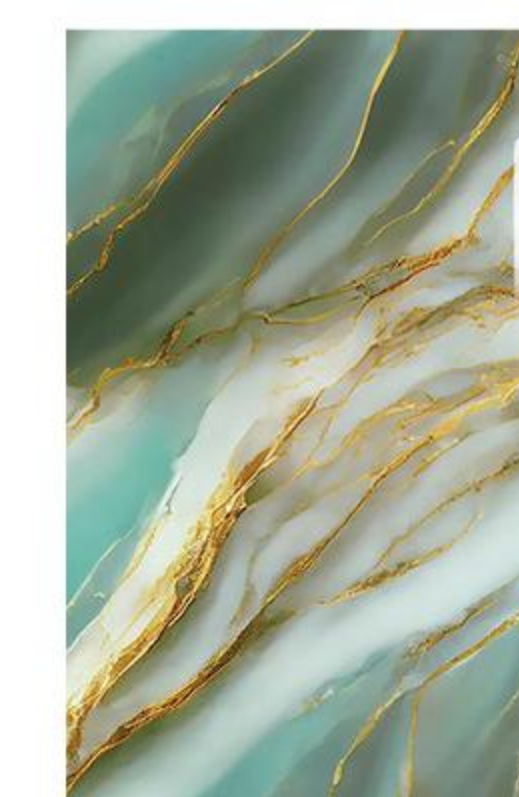

ZS-CZT118



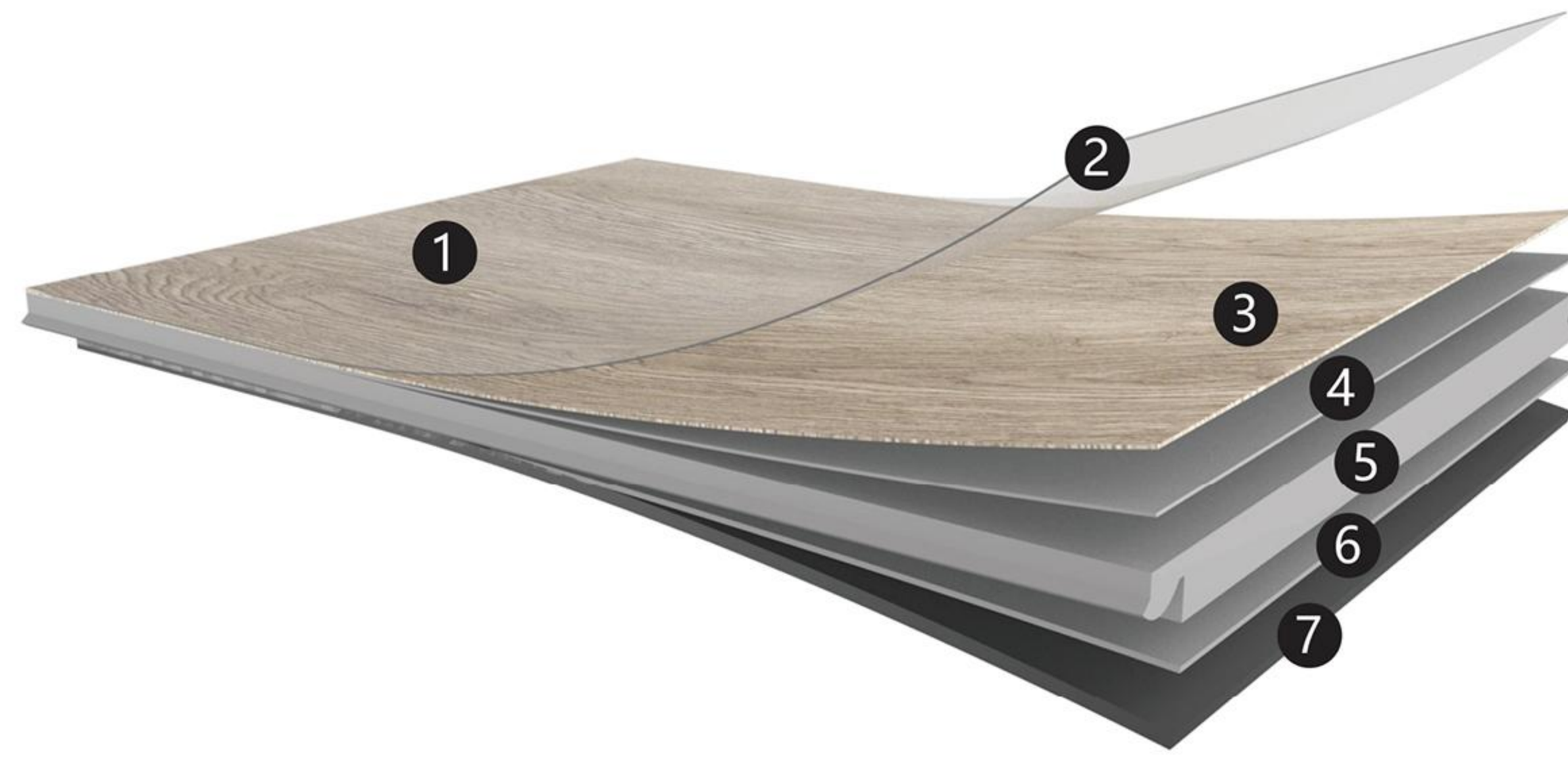

ESPC | Technical data sheet







技术数据表



CLICK SYSTEM SERIES

- ① UV Coating - UV 漆
- ② Wear layer - 耐磨层
- ③ Decor film layer - 彩膜层
- ④ LVT middle layer - LVT 中料
- ⑤ SPC rigid core - SPC 基材
- ⑥ LVT bottom layer - LVT 底料
- ⑦ Attached pad (IXPE, EVA) - 静音垫 (IXPE, EVA)

Size 规格	ESPC	Length from 590 to 1800mm Width from 118 to 600mm 长度从 590 到 1800 毫米 宽度 118 至 600 毫米
Thickness 厚度	ESPC	From 5.0mm to 8.0mm 从 5.0mm 到 8.0 毫米
UV Option UV 淋膜	ESPC	Ceramic Coating/Diamond Coating 陶瓷珠 / 晶钻
Wear Layer 耐磨层		0.15 / 0.30 / 0.50 mm
IXPE		1.0 / 1.5 / 2.0 mm
Surface Treatment 表面处理		Wood Emboss, EIR, Crystal, Granite 木纹、同步对花、水晶面、板岩纹
Edge Treatment 边缘处理		   

- 
Water proof
- 
Will not expand or contract
- 
Easy to Install
- 
Installation on any surface
- 
Covers minor floor imperfections
- 
Superior scratch resistance
- 
Reduces noise

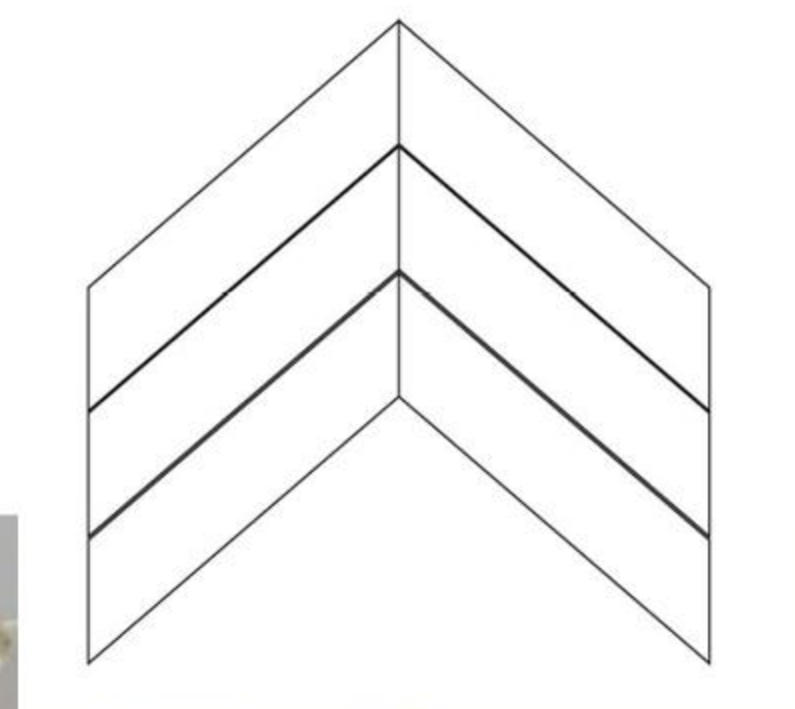

ZS-6457XL-006
FLOORING SIZE:
127X555MM

WATERPROOF LAMINATE FLOORING

Technical data sheet | 技术数据表



CLICK SYSTEM SERIES

- ① Melamine paper with Aluminum Oxide, Real Anti-scratch - 三氧化二铝耐磨层
- ② Realistic textures - 装饰纸
- ③ Click system for easy installation - 锁扣
- ④ Ultra-High density fiber core - 高密度基材
- ⑤ Waterproof technology - 防水技术
- ⑥ High-Strength melamine balance layer - 平衡纸
- ⑦ Pre-Attached premium pad - 地垫

Size 规格	Waterproof Laminate Floor	Length from 606 to 2400mm Width from 101 to 600mm 长度从 606 到 2400 毫米 宽度 101 至 600 毫米
Thickness 厚度	Waterproof Laminate Floor	7mm, 8mm, 10mm, 12mm
Wear Layer 耐磨层		Class AC1 to AC5 耐磨等级 AC1-AC5
IXPE		1.0 / 1.5 / 2.0 mm
Surface Treatment 表面处理		Feather, Embossed, EIR, Crystal, Piano Finish, Glossy 丝绸面、浮雕面、同步对花、 水晶面、钢琴面、高光面

Edge Treatment 边缘处理



Will not expand or contract



Easy to Install



Installation on any surface



Covers minor floor imperfections

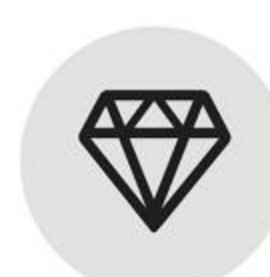

Superior scratch resistance



Reduces noise

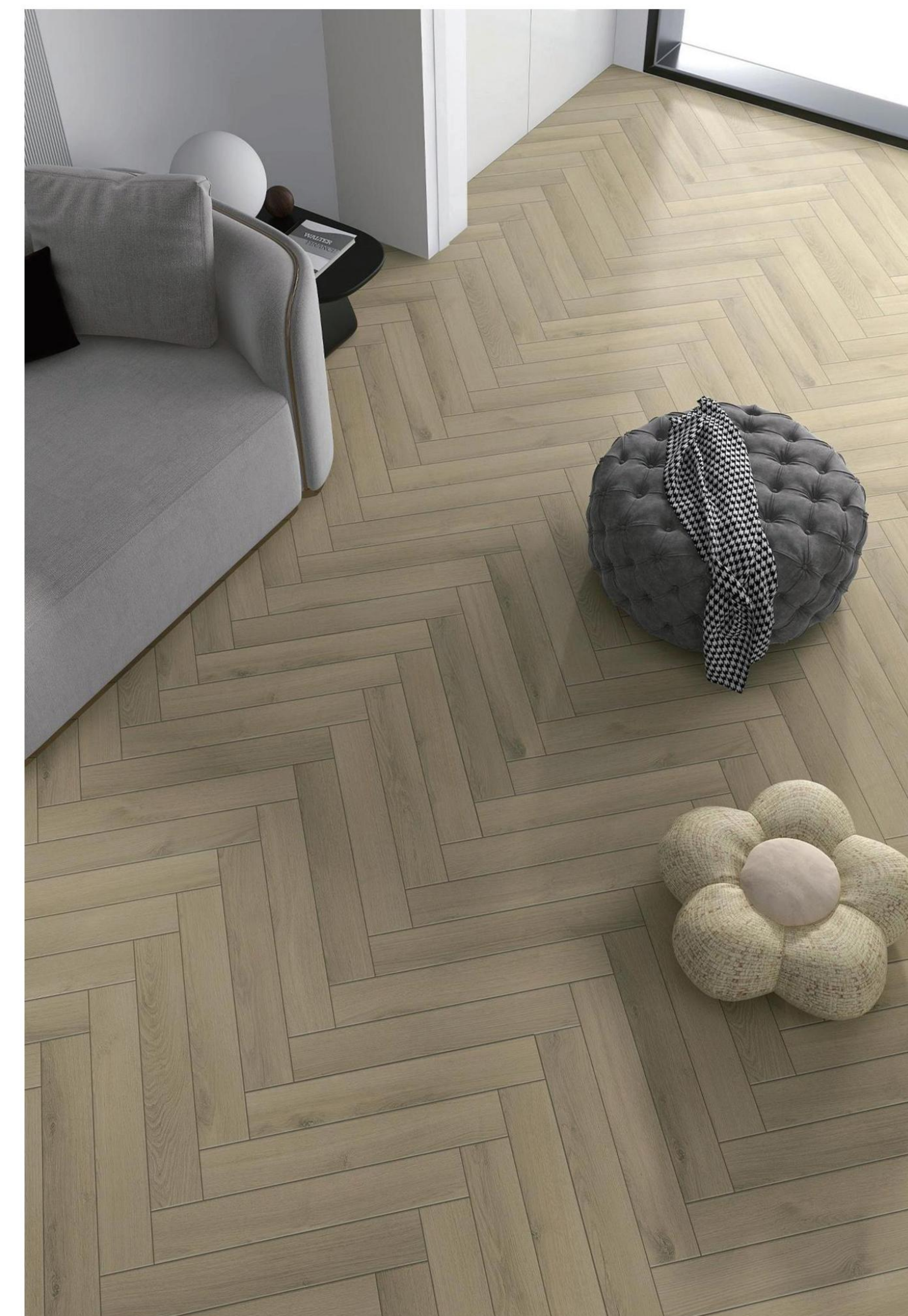
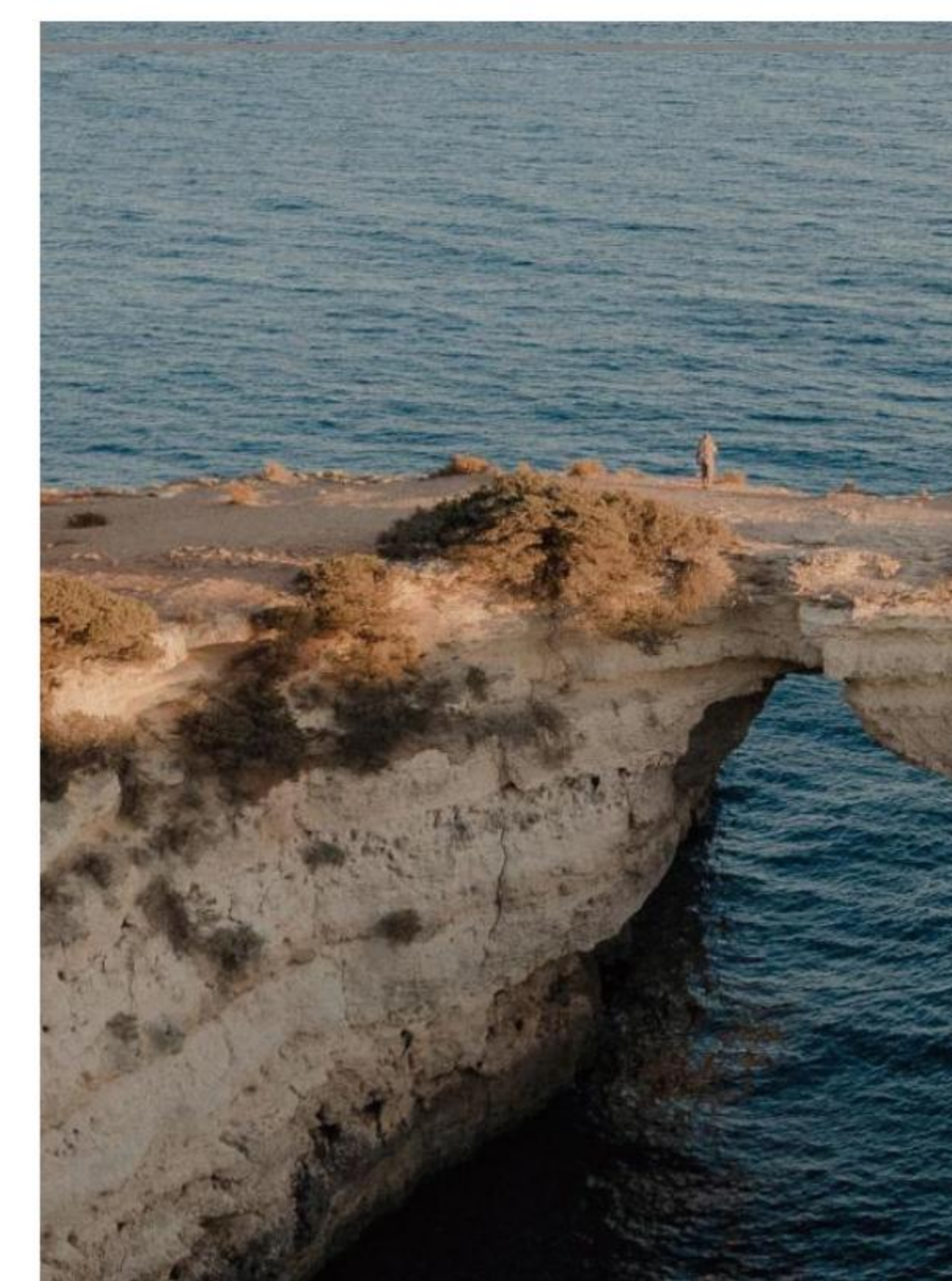

ZS-60009-2

SPEC: 1243X1523MM FLOORING
SIZE: 606X101MM

LAMINATE FLOORING | Technical data sheet

技术数据表









CLICK SYSTEM SERIES

- ① Wear Layer - 耐磨层
- ② Decorative Layer - 装饰纸
- ③ HDF Core - HDF 基材
- ④ Click System - 锁扣
- ⑤ Balance Layer - 平衡纸

Size 规格	Laminate Floor	Length from 606 to 2400mm Width from 101 to 600mm 长度从 606 到 2400 毫米 宽度 101 至 600 毫米
Thickness 厚度	Laminate Floor	7mm, 8mm, 10mm, 12mm
Wear Layer 耐磨层		Class AC1 to AC5 耐磨等级 AC1-AC5
IXPE		1.0 / 1.5 / 2.0 mm
Surface Treatment 表面处理		Feather, Embossed, EIR, Crystal, Piano Finish, Glossy 丝绸面、浮雕面、同步对花、 水晶面、钢琴面、高光面

Edge Treatment 边缘处理



- 
 Will not expand or contract
- 
 Easy to install
- 
 Installation on any surface
- 
 Covers minor floor imperfections
- 
 Superior scratch resistance
- 
 Reduces noise

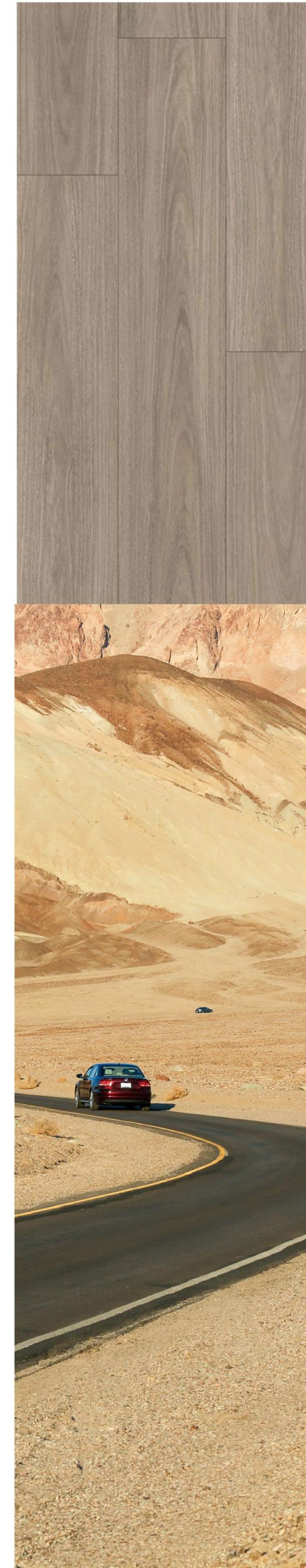

ZS-60008-5

SPEC: 1243X1523MM FLOORING
SIZE: 1218X197MM





LVT CLICK

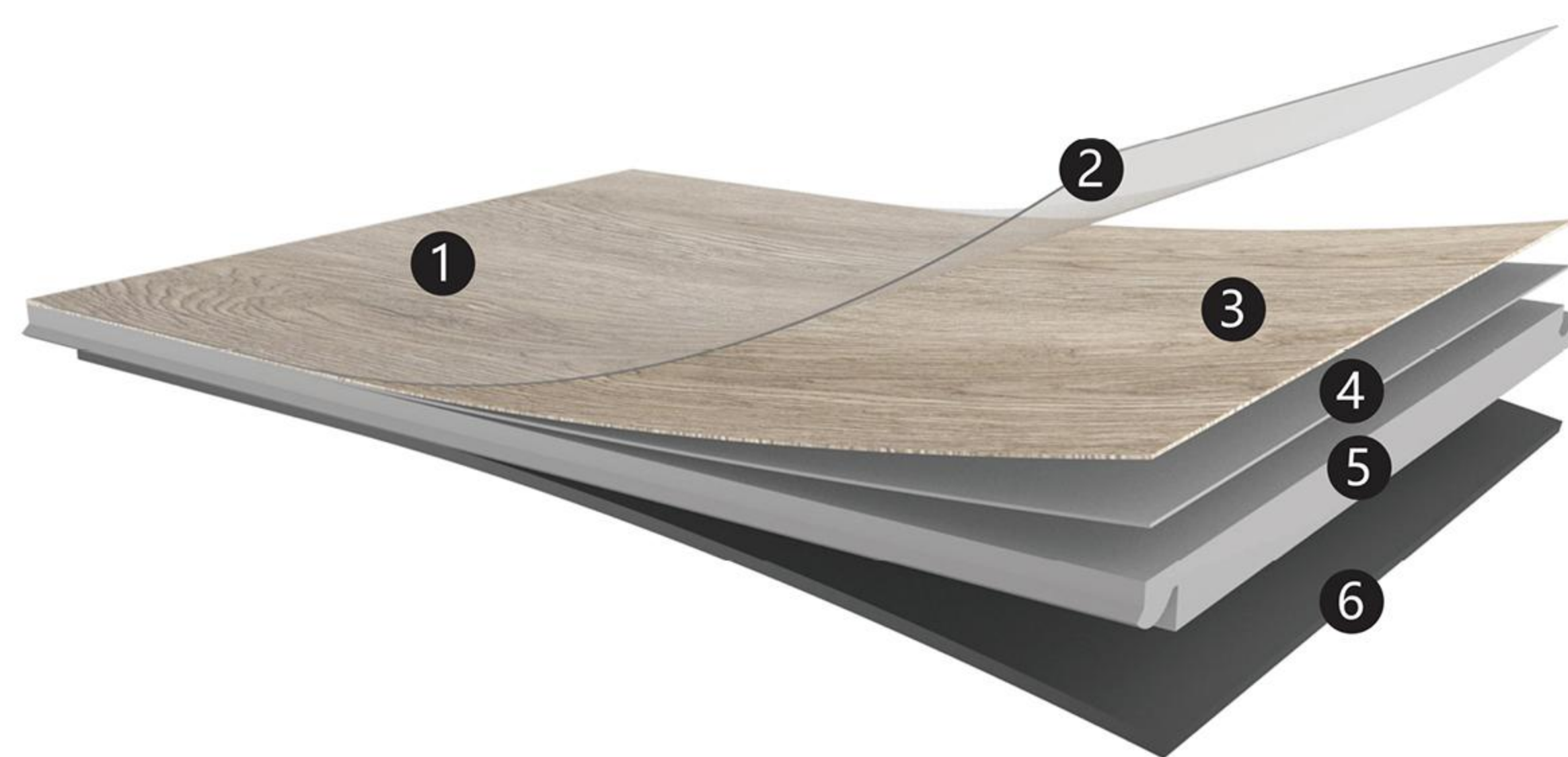





Technical data sheet
技术数据表



CLICK SYSTEM SERIES

- ① UV Coating - UV 漆
- ② Wear layer - 耐磨层
- ③ Decor film layer - 彩膜层
- ④ PVC layer - PVC 层
- ⑤ Fiber-Glass - 玻璃纤维
- ⑥ PVC Layer - PVC 层

Size 规格	LVT Click	Length from 590 to 1219.2mm Width from 118 to 609.6mm 长度从 590 到 1219.2 毫米 宽度 118 至 609.6 毫米
Thickness 厚度	LVT Click	From 1.0mm to 5.0mm 从 1.0mm 到 5.0 毫米
UV Option UV 淋膜	LVT Click	Ceramic Coating/Diamond Coating 陶瓷珠 / 晶钻
Wear Layer 耐磨层		0.15 / 0.30 / 0.50 mm
IXPE		1.0 / 1.5 / 2.0 mm
Surface Treatment 表面处理		Wood Emboss, EIR, Crystal, Granite 木纹、同步对花、水晶面、板岩纹
Edge Treatment 边缘处理		  

- 
Water proof
- 
Will not expand or contract
- 
Easy to Install
- 
Installation on any surface
- 
Covers minor floor imperfections
- 
Superior scratch resistance
- 
Reduces noise



LVT CLICK
ZS-YC1023-1

WOOD: OAK
SPEC: 1000X1570MM

WPC

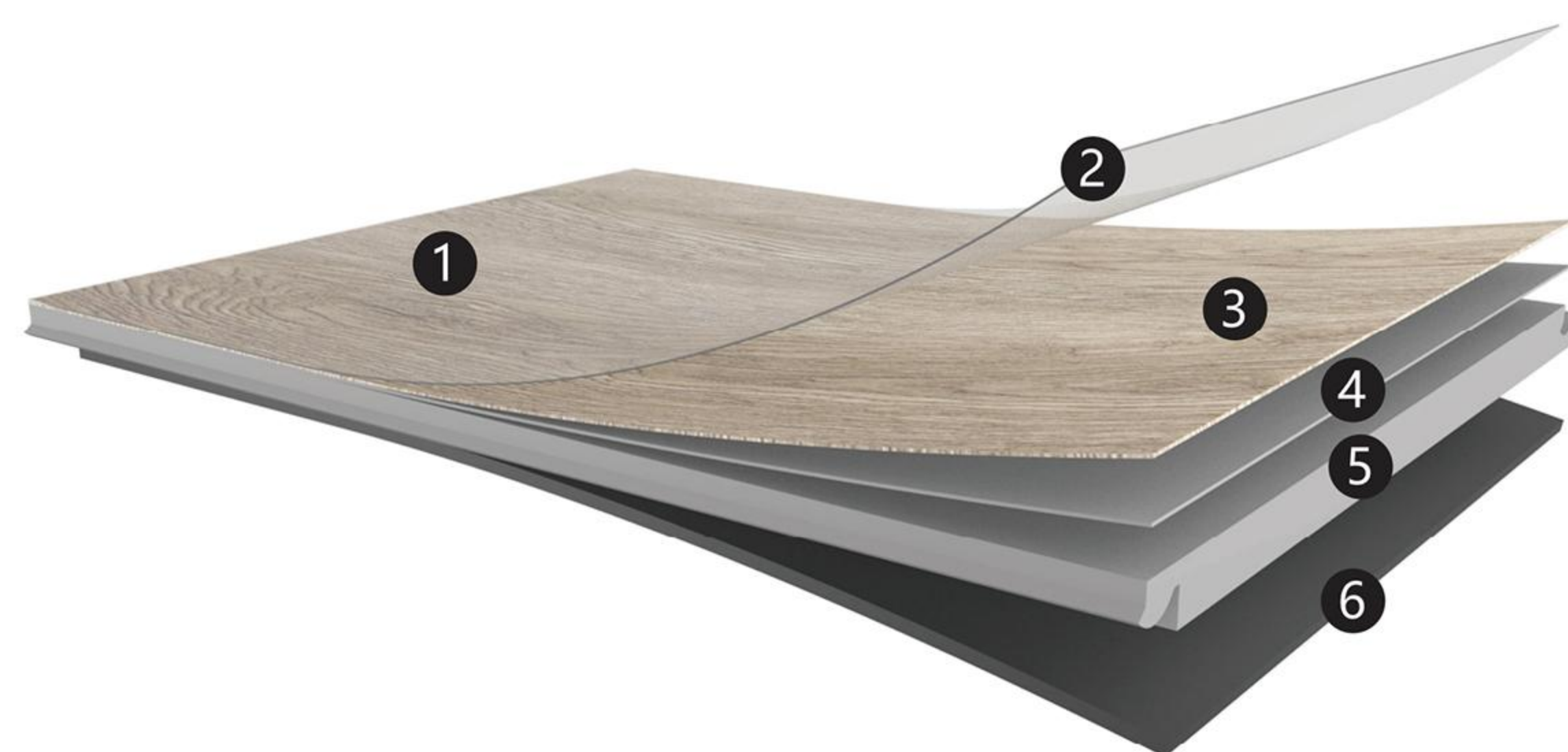

Technical data sheet
技术数据表



CLICK SYSTEM SERIES

- ① UV Coating - UV 漆
- ② Wear layer - 耐磨层
- ③ Decor film layer - 彩膜层
- ④ Middle layer - 中料
- ⑤ WPC Rigid core - WPC 基材
- ⑥ Attached pad - Coke, IXPE, EVA







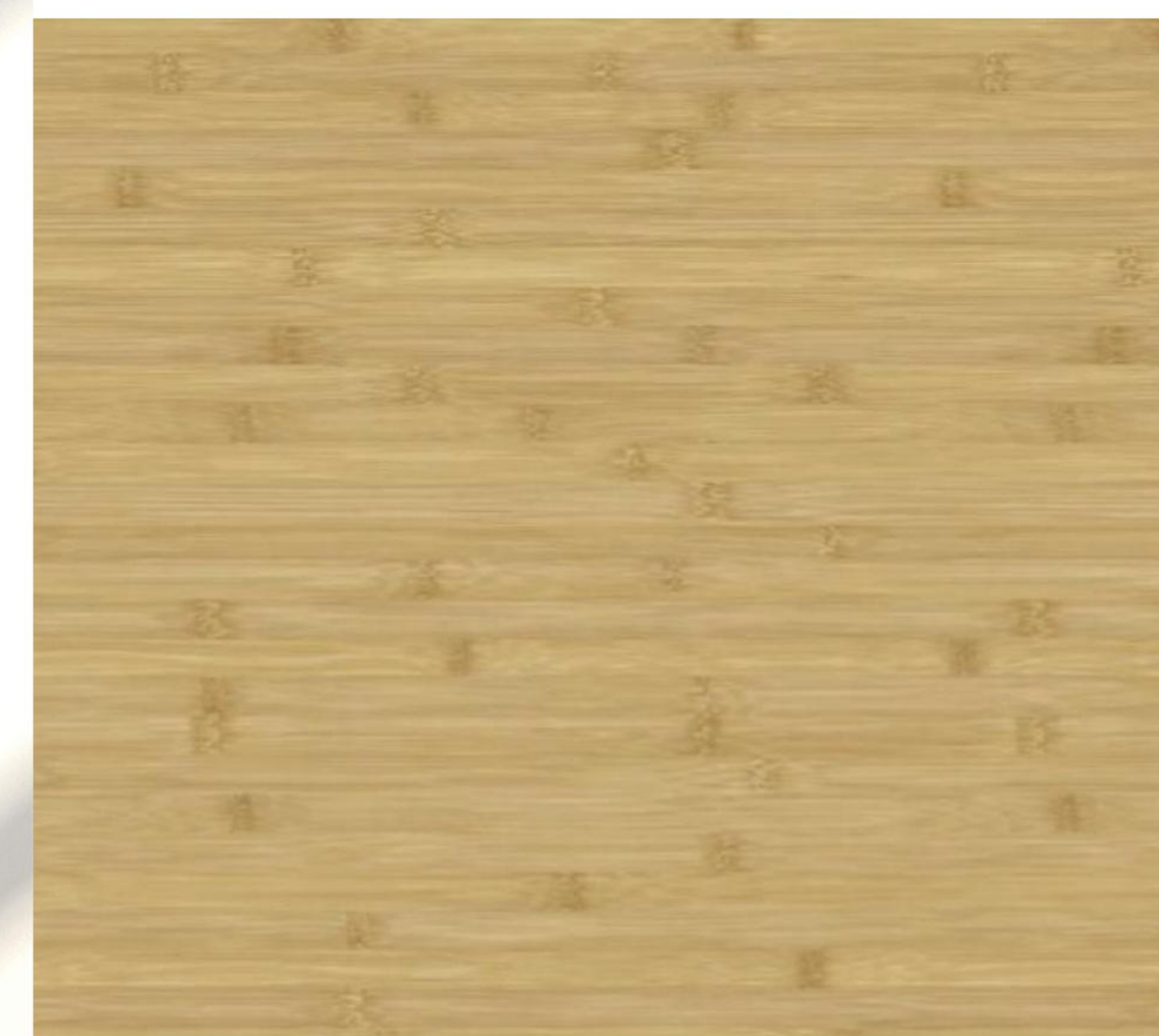

Size 规格	WPC	Length from 590 to 1800mm Width from 118 to 600mm 长度从 590 到 1800 毫米 宽度 118 至 600 毫米
Thickness 厚度	WPC	From 5.0mm to 12mm 从 5.0mm 到 12 毫米
UV Option UV 淋膜	WPC	Ceramic Coating/Diamond Coating 陶瓷珠 / 晶钻
Wear Layer 耐磨层		0.15 / 0.30 / 0.50 mm
IXPE		1.0 / 1.5 / 2.0 mm
Surface Treatment 表面处理		Wood Emboss, EIR, Crystal, Granite 木纹、同步对花、水晶面、板岩纹
Edge Treatment 边缘处理		  

WPC ZS-YC1019-3

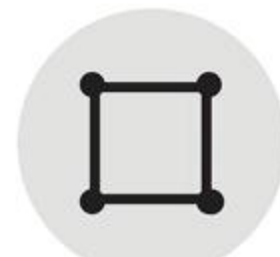
WOOD : BAMBOO GRAIN
SPEC : 1000*942MM



- 
Water proof
- 
Will not expand or contract
- 
Easy to Install
- 
Installation on any surface
- 
Covers minor floor imperfections
- 
Superior scratch resistance
- 
Reduces noise

UNDERLAYER FOR INSTALLATION OF ZS FLOORS



Waffle EVA

Description
High density EVA with embossed film (waffle)

Main Raw Material
Ethylene-vinyl acetate copolymer

Package
Nude/Pallet

Benefits
For soundproof
Protect the flooring from moisture arising from concrete
Water absorption 0.003lb/ft³
Provides firmness and comfort underfoot

Thickness	1.0/1.5/2.0mm	Roll Size	200 SF/18.6 SQM
Density	110 kg/m ³	Roll Size	100 SF/9.3 SQM
Length	8.5/16.91meters	STC Rating	72 db
Width	1.1 meters	IIC Rating	73 db

Description
High density IXPE with embossed film (waffle)

Main Raw Material
Chemical crosslinked polyethylene foam

Package
Nude/Pallet

Benefits
For soundproof
Protect the flooring from moisture arising from concrete
Water absorption 0.003lb/ft³
Provides firmness and comfort underfoot

Thickness	1.0/1.5/2.0mm	Roll Size	200 SF/18.6 SQM
Density	50 kg/m ³	Roll Size	100 SF/9.3 SQM
Length	8.5/16.91meters	STC Rating	72 db
Width	1.1 meters	IIC Rating	73 db



Waffle IXPE

Description
Cork Underlayment

Main Raw Material
Natural Cork

Package
Nude/Pallet

Benefits
Excellent sound and moisture protection
Eco-friendly, made from renewable materials
Self-leveling, providing stable support for flooring
Enhanced foot comfort with resilient cushioning

Thickness	1.0/1.5/2.0mm	Roll Size	200 SF/18.6 SQM
Density	180-220 kg/m ³	Roll Size	100 SF/9.3 SQM
Length	8.5/16.9 meters	STC Rating	50 db
Width	1.1 meters	IIC Rating	55 db



Cork

Description
EVA

Main Raw Material
Ethylene-vinyl acetate copolymer

Package
Nude/Pallet

Benefits
For soundproof
Protect the flooring from moisture arising from concrete
Water absorption 0.003lb/ft³
Provides firmness and comfort underfoot

Thickness	1.0/1.5/2.0mm	Roll Size	200 SF/18.6 SQM
Density	110 kg/m ³	Roll Size	100 SF/9.3 SQM
Length	8.5/16.91meters	STC Rating	66 db
Width	1.1 meters	IIC Rating	72 db

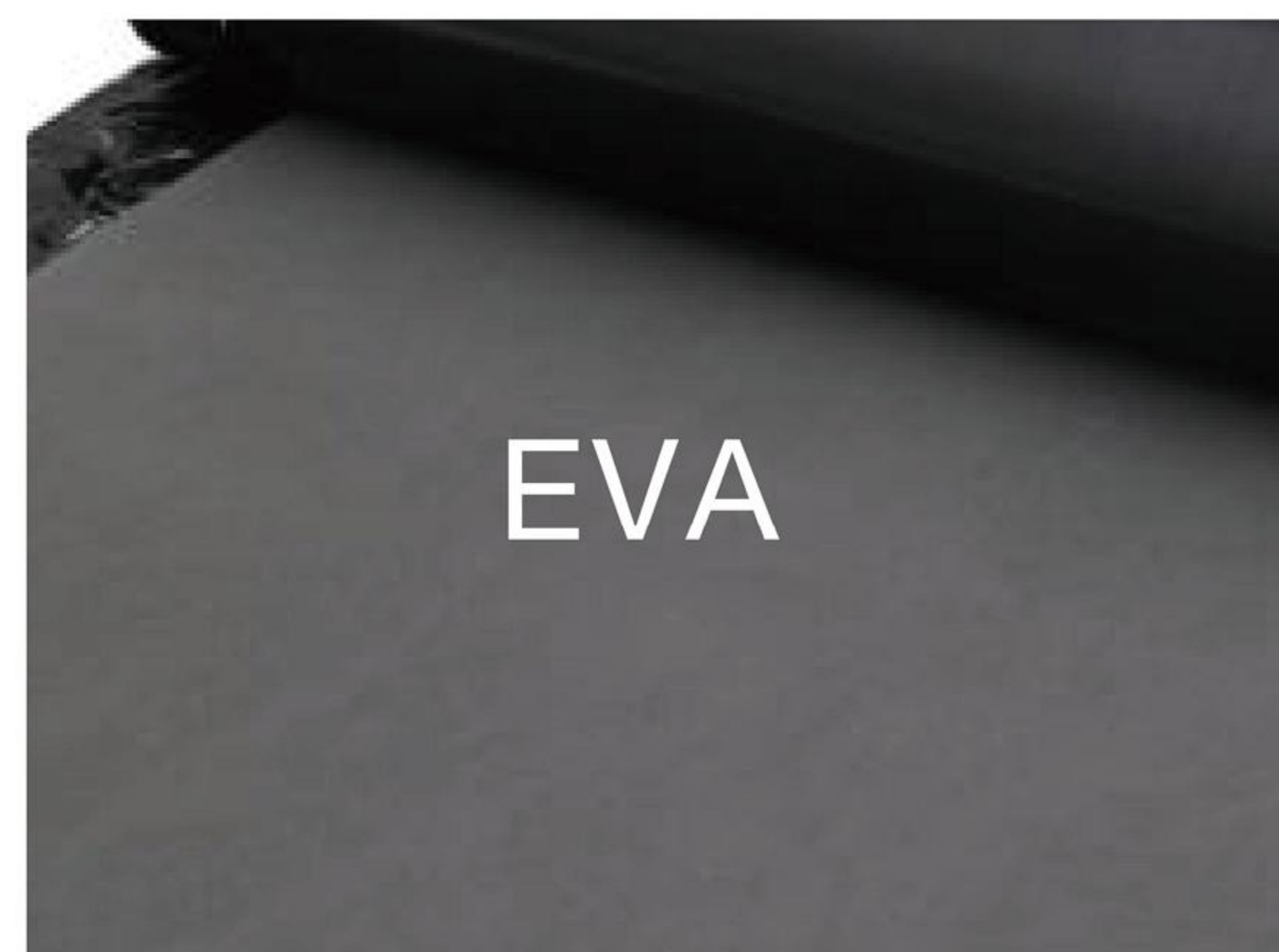

EVA

Molding & Trims

- Matching for SPC/LVT/WPC flooring thickness 4mm-7.5mm

	T-MOLDING
	Size: 2400*45*7mm
	Packing: 20pcs/box
	Weight: 14kgs/box

	REDUCER
	Size: 2400*43*7mm
	Packing: 20pcs/box
	Weight: 16kgs/box

	END-CAP
	Size: 2400*35*7mm
	Packing: 20pcs/box
	Weight: 12kgs/box

	QUARTER ROUND
	Size: 2400*28*16mm
	Packing: 25pcs/box
	Weight: 18kgs/box

	STAIR NOSE
	Size: 2400*55*18mm
	Packing: 10pcs/box
	Weight: 11kgs/box

	FLUSH STAIR NOSE
	Size: 2400*72*25mm
	Packing: 10pcs/box
	Weight: 25kgs/box

	SKIRTING 60
	Size: 2400*60*12mm
	Packing: 10pcs/box
	Weight: 16.5kgs/box

	SKIRTING 80
	Size: 2400*80*12mm
	Packing: 10pcs/box
	Weight: 18.5kgs/box

	7 END CAP
	Size: 2400*25*7mm
	Packing: 50pcs/box
	Weight: 10kgs/box

	UNDERLAYMENT
	Size: 16.9m*1.1m*1.5mm
	Packing: 1 roll/box
	Weight: 4.5kgs/roll

Technical Specifications

Characteristics	Standards	Result
Wear resistance	NALFA LF 01-2011	IP- 4000 cycles
Abrasion loss	EN-660-2	0.015 CLASS T
PCP	FD GEN/TR 14823:2006	NOT DETECTED
Colour fastness to light	EN ISO 105 B02	6
Slip Resistance	EN14041	R10
Fire Resistance	EN14041	Bf1-S1
Phthalate Test	ASTM D3421	NOT DETECTED
ROHS	2011/65/EU	NOT DETECTED
Staining Resistance	EN423	NOT AFFECTED
Determination of dimensional stability	ASTM F2199-09	WIDTH 0.02 % LENGTH 0.04 %
Squareness	ASTM F2055	SHORT 0.03mm, LENGTH 0.09mm
LENGTH	EN427	0.25mm
WIDTH	EN427	0.15mm
THICKNESS	EN428	0.15mm
Peel Strength	EN431	0.3MM, >58N, 0.5MM,>70N
Effect of a castor chair	EN425	NO VISIBLE DAMAGE
VOC emission	DIN EN ISO 16000-9	PASS
Residual indentation	ASTM F1914	0.40%
Resistant to Chemicals	ASTM F925	NO CHANGE
Resistant to heat	ASTM F1514	0.49 ΔE*
Resistant to light	ASTM F1515	0.87 ΔE*
Static coefficient of friction	ASTM C1028	DRY 0.94 ,WET 0.68
Static load resistant	ASTM F970	0.04 mm
Thermal Conductivity	ASTM C518	0.163 w/ m·k
Thermal Resistance	ASTM C518	0.033 (m ² ·k)/w

Technical Support

Q: What is the Expansion gaps for ZS Floors:

A: Even though ZS Floors will have very minimal expansion and contraction it is still required to leave 1/4" expansion space at least around the perimeter as well as all fixed objects (tile, fireplace, cabinets).

- If the installation area exceeds 80 feet in either direction transition pieces are needed.
- To cover your expansion space, ZS Floors carries matching moldings that include reducers, t-moldings, baseboards, quarter rounds. Matching stair parts are also available; including stair nosing, treads and risers.

Q: Is ZS Floors suitable for Radiant heat system, how to prepare and install.

A:

- Room temperature and relative humidity must be consistent with year-round living conditions for at least 5 days prior to installation
- Radiant heat system must be turned on and in operation for at least 3 days before installation.
- The system must be turned down to 65°F and maintained 24 hours prior to installation.
- Once install is complete, turn system back on and slowly bring back up to normal operating temperature over a period 4-5 days.
- Floor should never be heated over 85°F. Consult with your radiant heating system manufacturer to successfully limit the maximum temperature.
- Relative Humidity must be maintained between 20-80%.

Q: Floor Care Maintenance:

A: Do not use anything abrasive or harsh chemicals to clean the floor.

Do not drag furniture across the floor, use felt pads on chair and furniture legs.

Limit direct sunlight on floor by using curtains and blinds in areas that are exposed to high UV rays.

Although the ZS Floors is waterproof, it is still a best practice to avoid excessive moisture on the floor.

Therefore, we recommend soaking up spills immediately using a dry towel or dry mop.

Limited Warranty

Qualified product combine with proper installation and maintenance guarantees beauty and performance for years. ZS Floors offer limited warranties on staining, fading, wear and moisture resistance on condition that floors are properly installed in accordance with ZS installation instruction and by an authorized installer, and are properly maintained according to the maintenance instructions